



W-ClearPass 500 Hardware Installation Guide



Contacting Support

Website Support	
Main Website	dell.com
Support Website	support.dell.com
Dell Documentation	support.dell.com/manuals

Table of Contents

Section 1	Safety Notice and Warnings	3
Section 2	Ratings	3
Section 3	Electrical and General Safety Guidelines	4
Section 4	Unpacking the Appliance	6
Section 5	Site Preparation	7
Section 6A	4-Post Rack Installation	8
Section 6B	2-Post Rack Installation	9
Section 7	Rail Installation on the Appliance	10
Section 8	Installing the Appliance in the Rack	10
Section 9	Rear Panel Connections	11
Section 10	Front Panel Operation	11

1. Safety Notice and Warnings

FCC Notice

This device complies with part 15 of the FCC Rules. Operation is subject to the following two conditions:

1. This device may not cause harmful interference.
2. This device must accept any interference received, including interference that may cause undesired operation.

No Telecommunications Network Voltage (TNV)-connected PCBs shall be installed. This class A digital apparatus complies with Canadian ICES-003.

Cet appareil numérique de la classe A est conforme à la norme NMB-003 du Canada.

CE Mark Warning

This is a Class A product. In a domestic environment, this product may cause radio interference, in which case the user may be required to take adequate measures.

VCCI Warning

This is a product of VCCI Class A Compliance.

注意

この装置は、情報処理装置等電波障害自主規制協議会（VCCI）の基準に基づく第一種情報技術装置です。この装置を家庭環境で使用すると電波妨害を引き起こすことがあります。この場合には使用者が適切な対策を講ずるよう要求されることがあります。

Environmental Warning

Perchlorate Material - special handling may apply. See www.dtsc.ca.gov/hazardouswaste/perchlorate. This notice is required by California Code of Regulations, Title 22, Division 4.5, Chapter 33: Best Management Practices for Perchlorate Materials. This product/part includes a battery that contains perchlorate material.

2. Ratings

V: 100 - 240 VAC (auto-range)

Hz: 50/60

A: 5 Max

3. Electrical and General Safety Guidelines

CAUTION

This appliance is intended for installation in restricted areas only. Initial setup and maintenance should be performed by qualified personnel.

CAUTION

Power down the appliance following the operating system's proper power down procedure from the front panel. Unplug all AC power cord(s) before servicing.

CAUTION

To avoid electrical shock, check the power cords as follows.

- This product is to be installed in Restricted Access Location only.
- Use the exact type of power cords required.
- Use power cord(s) that came with safety certifications.
- Power cord(s) must comply with AC voltage requirements in your region.
- The power cord plug cap must have an electrical current rating that is at least 125% of the electrical current rating of this product.
- The power cord plug cap that plugs into the AC receptacle on the power supply must be an IEC 320, sheet C13, type female connector.
- Plug the power cord(s) into a socket that is properly grounded before turning on the power.

CAUTION

Required operating conditions for the appliance are -

- Temperature: 10 to 35°C.
- Humidity, non-condensing: 8 to 90%.

CAUTION

Risk of explosion if the battery is installed upside down or is replaced by an incorrect type. Dispose of used batteries according to the instructions.

DISPOSING OF BATTERY BACKUP UNITS - IF APPLICABLE

WARNING

If the BBU is damaged in any way, toxic chemicals may be released.

The material in the battery pack contains heavy metals that can contaminate the environment. Federal, state, and local regulations prohibit the disposal of rechargeable batteries in public landfills. Be sure to recycle the old battery packs properly. Comply with all applicable battery disposal and hazardous material handling laws and regulations in the country or other jurisdiction where you are using the BBU.

WARNING

There is danger of an explosion if the battery is incorrectly replaced. Replace it only with the same or equivalent type recommended by the manufacturer. Dispose of used batteries according to the manufacturer's instructions.

3. Electrical and General Safety Guidelines (continued)

WARNING

Disconnect the power supply at the circuit breaker before accessing any components. Turning off the system power supply switch does not reduce the risk of electrical shock from the power supply terminal block.

CAUTION

- To prevent the unit from overheating, never install the appliance in an enclosed area that is not properly ventilated or cooled. For proper airflow, keep the front and back sides of the appliance clear of obstructions and away from the exhaust of other equipment.
- Be aware of the locations of the power switches on the chassis and in the room, so you can disconnect the power supply if an accident occurs.
- Take extra precautionary measures when working with high voltage components. Do not work alone.
- Before removing or installing main system components, be sure to disconnect the power first. Turn off the system before you disconnect the power supply.
- Use only one hand when working with powered-on electrical equipment to avoid possible electrical shock.
- Use rubber mats specifically designed as electrical insulators when working with computer systems.
- The power supply or power cord must include a grounding plug and must be plugged into grounded outlets.

CAUTION

Electric Static Discharge (ESD) can damage electronic components. To prevent damage to your system board, it is important to handle it very carefully. The following measures can prevent ESD damage to critical components.

- Use a grounded wrist strap designed to prevent static discharge.
- Keep all components and printed circuit boards (PCBs) in their antistatic bags until ready for use.
- Touch a grounded metal object before removing the board from the antistatic bag.
- Do not let components or PCBs come into contact with your clothing, which may retain a charge even if you are wearing a wrist strap.
- Handle a board by its edges only; do not touch its components, peripheral chips, memory modules or contacts.
- When handling chips or modules, avoid touching their pins.
- Put the motherboard and peripherals back into their antistatic bags when not in use.
- For grounding purposes, make sure your computer chassis provides excellent conductivity between the power supply, the case, the mounting fasteners and the motherboard.

4. Site Preparation

Setup location, rack and appliance precautions

- **Elevated Operating Ambient Temperature** - If installed in a closed or multi-unit rack assembly, the operating ambient temperature of the rack environment may be greater than room ambient temperature. Therefore, consideration should be given to installing the equipment in an environment compatible with the maximum ambient temperature (T_{ma}) specified by the manufacturer.

Always keep the rack's front door and all panels and components on the appliances closed when not servicing to maintain proper cooling.

- **Reduced Air Flow** - Installation of the equipment in a rack should be such that the amount of air flow required for safe operation of the equipment is not compromised. Leave enough clearance, approximately 25 inches in the front, and 30 inches in the back of the rack to enable you to access appliance components and allow for sufficient air flow.
- **Mechanical Loading** - Mounting of the equipment in the rack should be such that a hazardous condition is not achieved due to uneven mechanical loading.

ALL RACKS MUST BE MOUNTED SECURELY. Ensure that all leveling jacks or stabilizers are properly attached to the rack. If installing multiple appliances in a rack, make sure the overall loading for each branch circuit does not exceed the rated capacity.

Do not slide more than one appliance out from the rack at a time. Extending more than one appliance at a time may result in the rack becoming unstable. Install your appliance in the lower part of the rack because of its weight and also for ease in accessing appliance components.

- **Circuit Overloading** - Consideration should be given to the connection of the equipment to the supply circuit and the effect that overloading of the circuits might have on overcurrent protection and supply wiring. Appropriate consideration of equipment nameplate ratings should be used when addressing this concern.
- **Reliable Earthing** - Reliable earthing of rack-mounted equipment should be maintained. Particular attention should be given to supply connections other than direct connections to the branch circuit (e.g. use of power strips).

Install near appropriate AC outlets, and Ethernet hubs or individual jacks. Be sure to install an AC Power Disconnect for the entire rack assembly. The Power Disconnect must be clearly marked. Ground the rack assembly properly to avoid electrical shock.

5. Unpacking the 4-Post Rack Installation Assemblies

Before you begin verify the ship kit includes one of the following installation assemblies:

- One power cord
- Installation hardware (shown below)
- The 4-post and/or 2-post rack rail and bracket assemblies

4-POST RACK INSTALLATION HARDWARE

Ten (10) M6 x 6
Phillips Head Screws

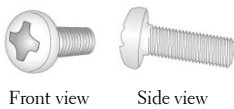

Ten (10) Rack Clips

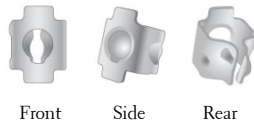

2-POST RACK INSTALLATION HARDWARE

Eight (8) M5 x 12
Flat Head Screws

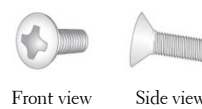

Eight (8) M5 x 12
Cone Washers

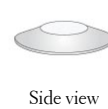

BOTH RACKS INSTALLATION HARDWARE

Twenty-two (22) M4 x 4
Truss Head Screws



 **NOTE:** Use the hardware supplied with your specific rack if different from the hardware supplied in this kit.

The appliance rack mounting components consist of two sections common to both rack types:

- A set of adjustable outer fixed rack rail assemblies that attach directly to the rack(s).
- A set of inner fixed chassis rail that attach to the appliance (these must be removed from each of the adjustable rack rail assemblies).

 **NOTE:** See Step 1 in Section 6A on page 8 or Step 1 in Section 6B on page 9 to see these rack assemblies.

The 4-post rack assembly consists of:

- A set of long, fixed rack brackets (A).
- A set of short, fixed rack brackets (B).

 **NOTE:** See Section 6A on the page 8 of this document for the rack bracket assemblies A and B.

The 2-post rack assembly consists of:

- A set of long, fixed rack brackets (A).
- Two sets of short rack brackets (B and C). Set (C) has threaded holes (for placement in the front) to allow the appliance to be secured in the rack.

 **NOTE:** See Section 6B on page 9 of this document for rack assemblies A, B and C.

6A. 4-Post Rack Installation

Unpack the appliance and locate the mounting hardware

Step 1

- Remove the inner fixed chassis rails from the outer fixed chassis rails.
- Pull each one out as far as possible.
- Depress the locking tab to pull the inner rail completely out.
- Put these rails aside for later installation on the appliance.

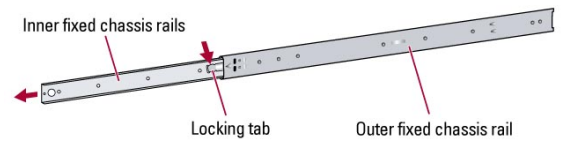

Step 2

- Attach the long (A) and short (B) brackets to the outer fixed chassis rails as shown, using the shorter ones in the front and the longer ones in the rear.
- Leave approximately one inch of space between the front end of the shorter bracket and the outer fixed chassis rail in the front. The two vertical holes in the front brackets align with the threaded holes in the front of the rails.
- Secure with four M4 x 4 screws, two in the front and two in the rear on each side.

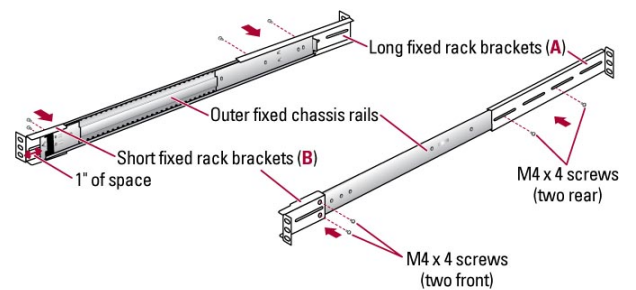

Step 3

Rack Clip Installation:

- A. In the front, install three rack clips through each of three holes of the rack as shown.
- B. In the back, install two rack clips in the top and bottom of three holes that are level in height with the front rack clip installation. This will ensure for proper alignment when installing the assembled rack rail components to the rack.

 **NOTE:** The tabs on each rack clip should be on the top and bottom to help stabilize the final installation process. No tools are needed to install the rack clips. Firmly press them into place.

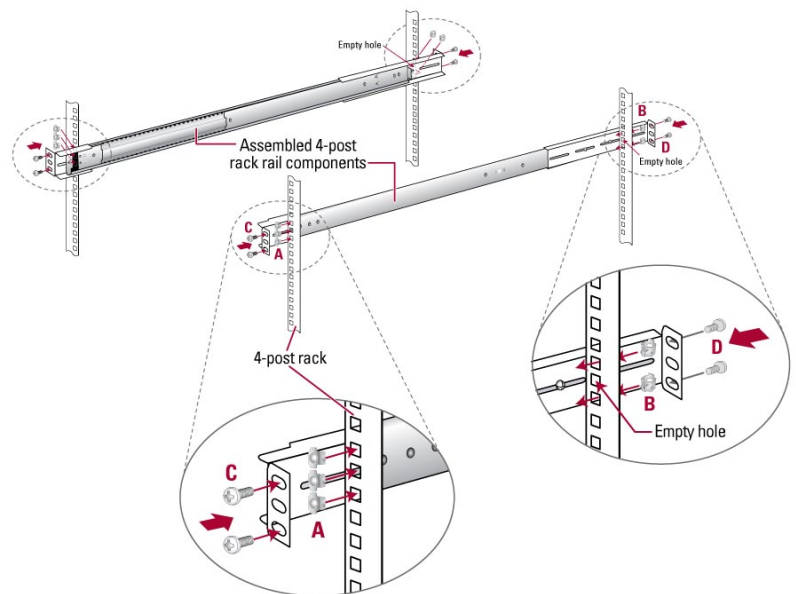

Step 4

Rack Clip Installation:

- B. In the front, insert and tighten two M6 x 6* screws through the top and bottom holes of the assembled rack rail components leaving the center hole empty to secure the appliance in the rack.
- D. In the rear, insert and tighten two M6 x 6* screws through the top and bottom holes of the assembled rack components into the rack clips as shown. The center holes in the rear will remain empty.

 **NOTE:** Use the hardware supplied with your specific rack if different from the hardware supplied in this kit.

Once you have completed mounting the brackets and outer fixed chassis rails to the 4-post rack, proceed to **Section 7** on page 10, **Rail Installation on the Appliance**.

6B. 2-Post Rack Installation

Unpack the appliance and locate the mounting hardware

Step 1

- Remove the inner fixed chassis rails from the outer fixed chassis rails.
- Pull each one out as far as possible.
- Depress the locking tab to pull the inner rail completely out.
- Put these rails aside for later installation on the appliance.

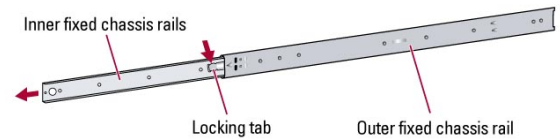

Step 2

- Attach the long fixed (A) and the small (B) brackets to the 2-post rack.
- Mount the short brackets in the front, and the longer brackets in the back using two M5 x 12* flat head screws and cone washers for each bracket as shown, using the top and bottom holes.
- Make sure the brackets and screws are aligned in the rack not only in the front and back, but are level in height on the left and right sides for proper alignment to allow accurate appliance installation.

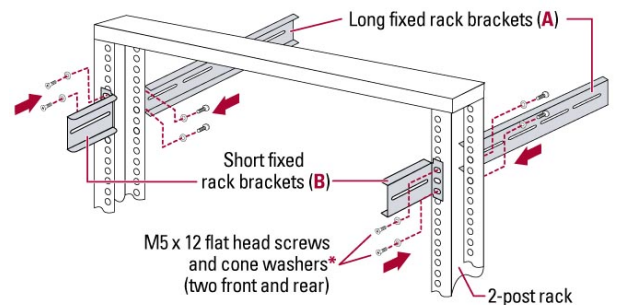

*  **NOTE:** Use the hardware supplied with your specific rack if different from the hardware supplied in this kit.

Step 3

- Slide each of the outer fixed chassis rails into the left and right fixed brackets and loosely secure with four M4 x 4 truss head screws on each side (shown with red dotted lines).
- Leave enough of the outer fixed rails extended in the front to attach fixed rack brackets (C) to the rack rails using two M4 x 4 truss head screws on each side (shown with the blue dotted lines). There should be approximately one inch of space between brackets (B) and (C) in the front.
- Once all screws are in place, tighten each one to secure the outer fixed chassis rails in place.

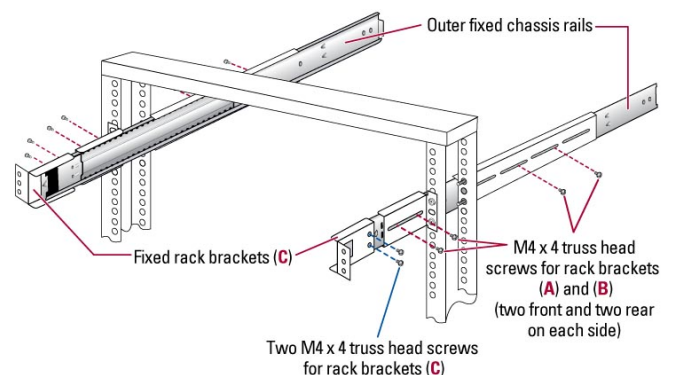

Once you have completed mounting the brackets and outer fixed chassis rails to the 2-post rack, proceed to **Section 7** on page 10, **Rail Installation on the Appliance**.

7. Rail Installation on the Appliance

Locate the fixed chassis rails that were put aside in 6A or 6B, Step 1 on pages 8 or 9.

- Mount the inner fixed chassis rail side of the appliance using three 1 truss head screws on the left and right sides as shown.

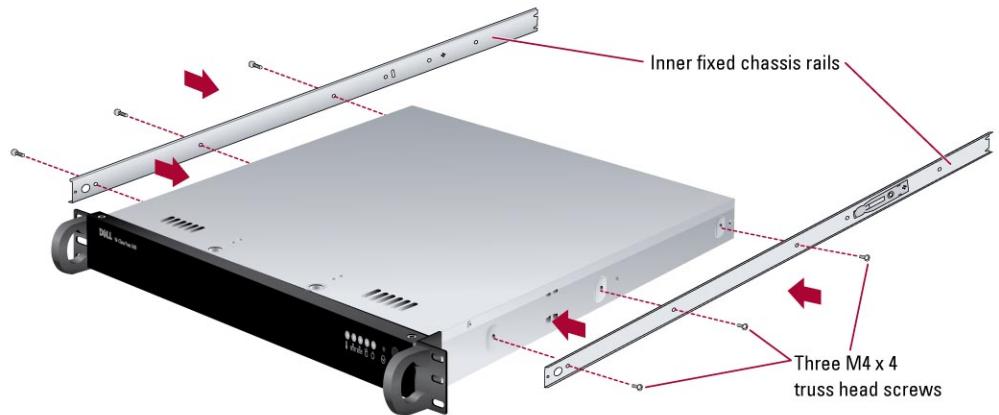

8. Installing the Appliance in the Rack

- Align the inner fixed chassis appliance with the outer fixed rails previously installed in the rack.
- Carefully slide the appliance rails until you hear them click.
- Push the appliance all the way back into the rack until it stops.
- Secure the unit in the rack by inserting and tightening two M6 x 6* screws, one on each side.

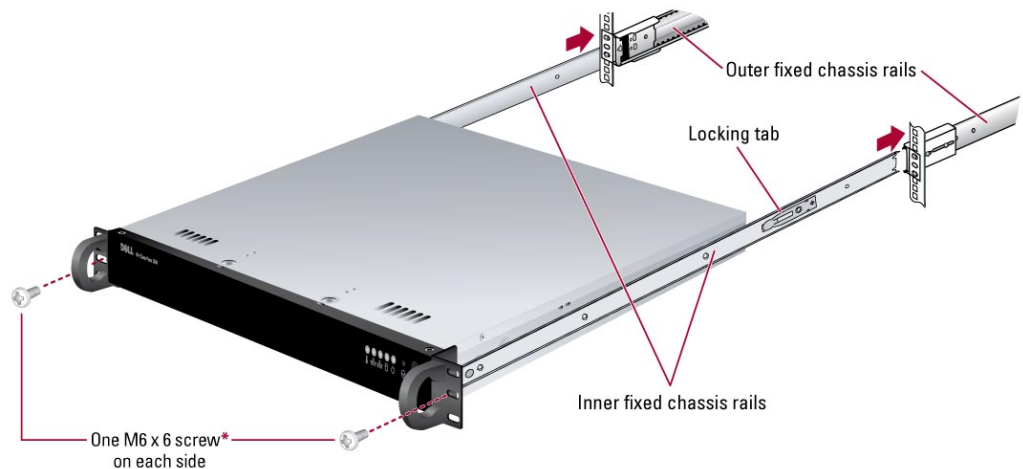

*  **NOTE:** Refer to your rack's mounting hardware for the proper size and type of screws to secure the appliance in the rack.

 **NOTE:** When removing the appliance from either rack type, you will need to press down on the locking tab in order to release it from the rack. Carefully slide it out supporting the unit on both sides at all times.

9. Rear Panel Connections

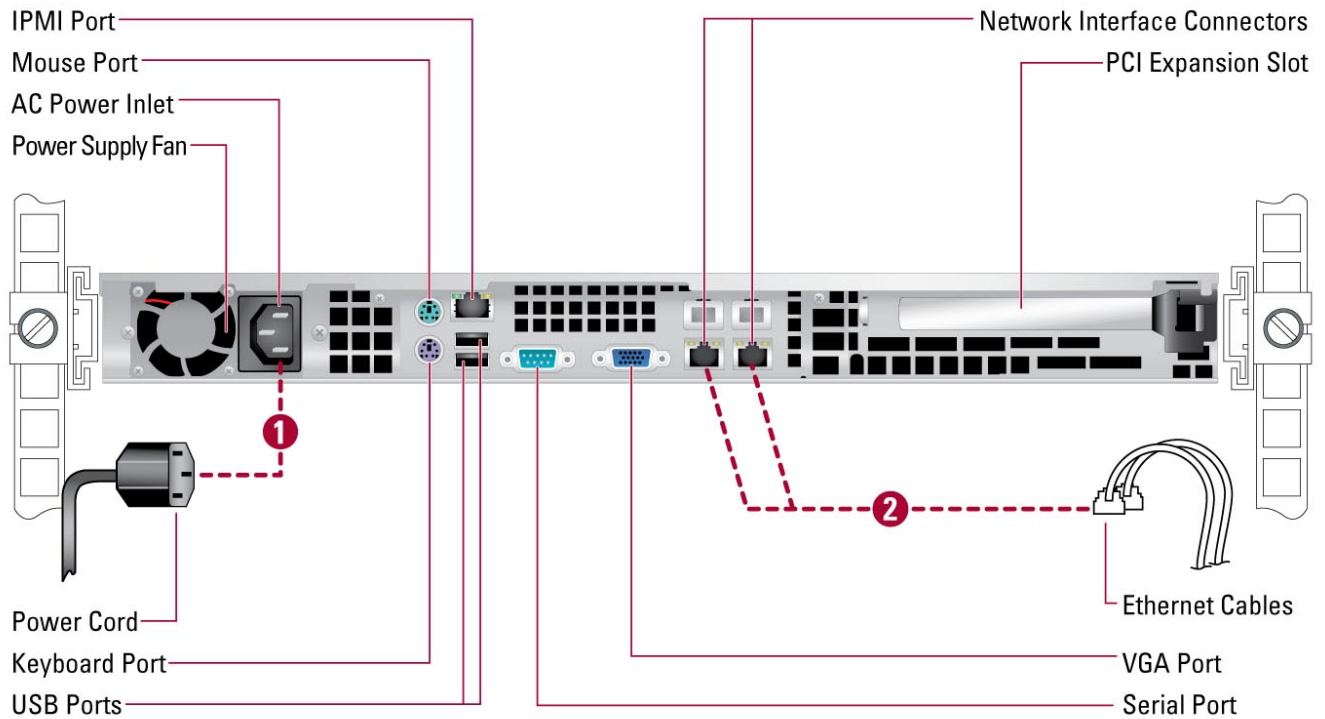

- **Step 1:** Connect the power cord.
- **Step 2:** Connect the Ethernet cables.
- **Step 3:** Connect any other required cables.

CAUTION

Slide rail/mounted equipment is not to be used as a shelf or a work space.

10. Front Panel Operation



Power on the appliance.

The power button is the last button on the right side on the front of the appliance.



P/N: 509-2125-00



REV: 0A